

UQD (UQDZ Intelligent) Electric Ball Float Liquid Level Transmitter

Summary

UQD series electrical ball-float level transmitters belong to the electrical type instruments, including measuring unit and signal transmitting unit. The meter can be classified into 90 ordinary type, 91 big rotating angle type, 92 external mounting type three types according to measuring unit structure. Also can it be classified into analog (UQD.A) type and intelligent (UQD.Z) type according to the signal transmitting unit. UQD.Z type transmitter not only can directly display local liquid level change, but also can it transmit 4-20mA analog signal on which digital signal being conformity with HART protocol is superimposed. All the transmitters' head cases adopt modern fashionable case design and shape beautifully with all the working chambers separated. The meters are safe and reliable. They widely applies to measure various kinds of liquid level and transmit liquid level change signal, such as sticky, dirty, explosive, corrosive and other fluid. They are perfect instruments for liquid level measurement in production process in petroleum, chemical, metallurgy, power industry and light industries.

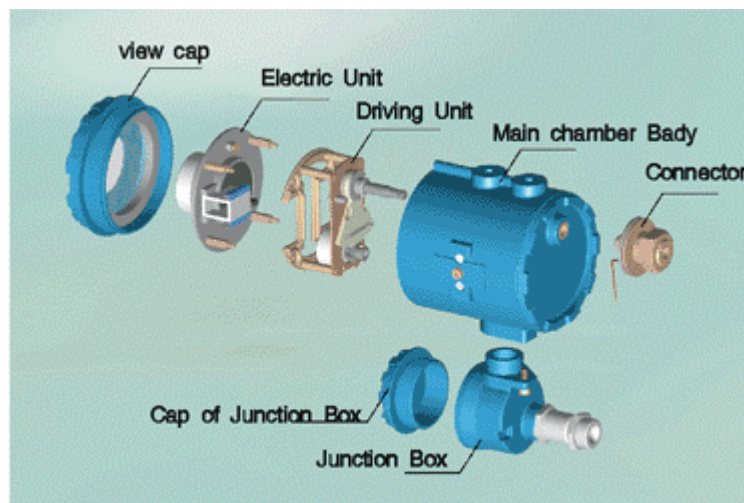

UQD electric float-ball transmitter head breakdown drawing

Principle of Operation

The measuring unit of UQD series electric ball-float liquid level transmitter includes floating ball, balance lever, balance weights (these three elements comprise a torque balance device). The floating ball can float up and down freely with liquid level changing. When the liquid level change, the floating ball position changes correspondingly and drive the main shaft to rotate through the floating ball connecting rod. The angular displacement sensor in the case couples with the main shaft via a pair of gears. In this way, the changes of the liquid level can be converted into electric signal that will be turned into standard current signal in direct proportion by the electronic circuit in the case.

Main Performances and Qualifications

Performance and qualifications	Analog Meter (transmitter head)	Intelligent Meter (transmitter head)
Supplying voltage	24V DC	24V DC
Output signal	4 ~ 20mA	4 ~ 20mA+HART protocol
Precision class	1.5	0.5, 1.0

Local indication	Indicating needle	Indicating needle + LCD
Setting methods	Local knob	Local switch, Debug software + PC, Communicator (remote)
Damp selection	Non	0-199s
Local and remote configuration	Non	Yes
Alarm for exceeding range Diagnosis for failure	Non	Yes
Ambient temperature	-40 ~ 80	-30 ~ 70 (for LCD)
Operating temperature	-40 ~ 225 (without radiator), 225 ~ 450 (with radiator)	
Load resistance	See load chart	
Diameter of the floating ball	230	
Nominal pressure	4.0, 6.3MPa	
Nominal diameter	DN250	
Flange standard	JB/T82.2-94 (raised face flange)	
Wetted material	Flange: steel or 1Cr18Ni9Ti, Others: 1Cr18Ni9Ti	
Fluid density	0.55g/cm ³	
Power supply inlet	M20*1.5 (female thread)	
Protection class	IP65	

Structure and Installation Dimensions

UQD.A-90 analog meter (head), UQD.Z-90 intelligent meter (head) ordinary type electric ball-float liquid level transmitter

Design Features

They are suitable for working environment (or container) in which the rod is needed to be long and the range is small. They have simple structure with installation easy and convenient. The angular rotating range (angular home range) 35°, when operating angle range is not less than 8°, signal 4-20mA can be output.

Installation Dimensions

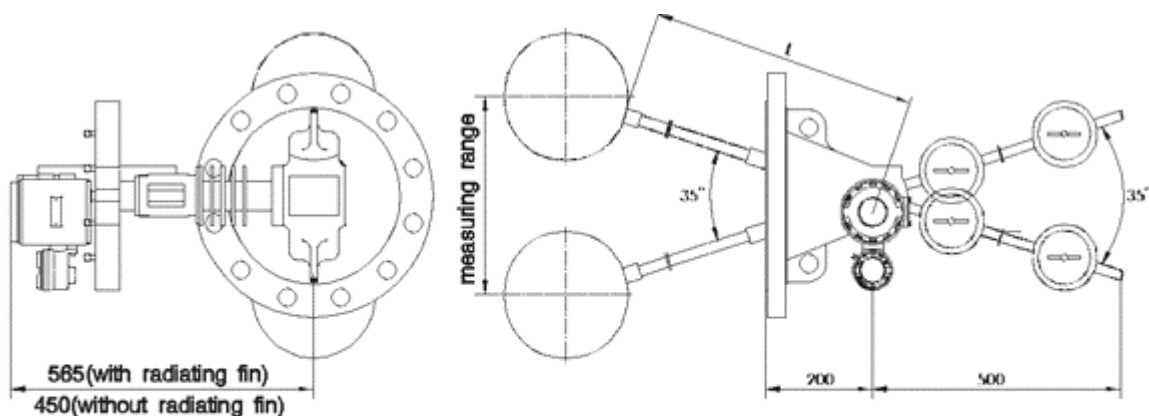

UQD.A-90
 UQD.Z-90 Outline sketch and Installation Dimensions of Ordinary Type

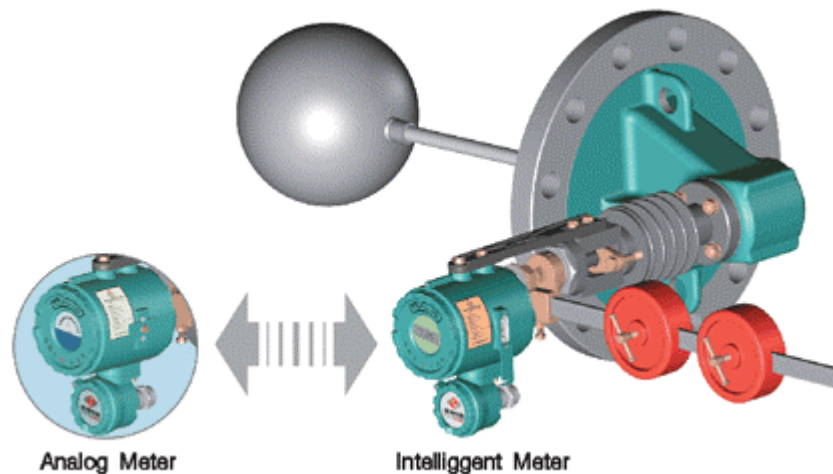

UQD.A-90,UQD.Z-90 Common Type Outline

UQD.A – 91 analog meter (head) type, UQD.Z – 91 intelligent meter (head) type big angle type electric ball-float liquid level transmitter

Design Features

In order to solve the problem that there is no way for the transmitter working in volume limited container to increase the measuring range by being extended the length of the ball connecting rod, our company developed and manufactured 91 type electric ball-float liquid level transmitter which maximum operating angle can reach 80°. So we resolve the problem that using short rod to accomplish big range. This technology has been granted a national patent. The patent number is ZL96 2 25811.3

Installation Dimensions

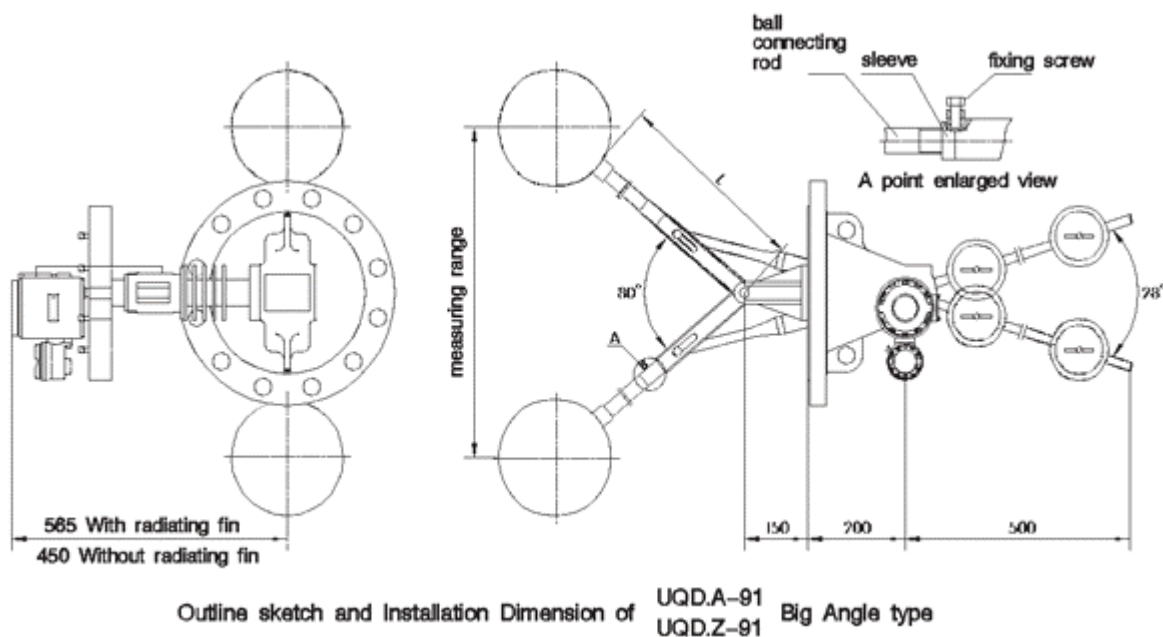

Note: * the longest length of ball connecting rod is not longer than 1130mm.

For large volume container, it is forbidden to extend the rod length at will to increase the measuring range.

* the minimum diameter of container should not less than 400mm.

Here we remind our customer that the limit length of the ball connecting rod is 400mm.

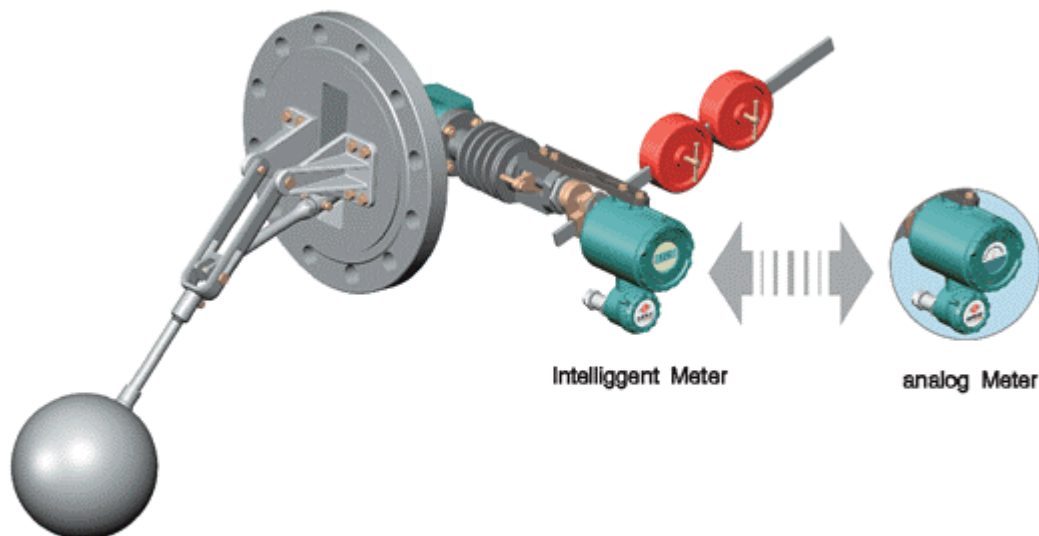

UQD.A-91 Big Angle Type Outline
UQD.Z-91

UQD.A-92 analog meter (head) type, UQD.Z- 92 intelligent meter (head) type external mounting type electric ball-float liquid level transmitter.

Design Feature

92 external mounting type transmitter has the same measuring unit and transmission unit as 90 ordinary type transmitter. The difference is for external type transmitter adding a external measuring chamber (see the figure) that connects the fluid container through pipeline. So the fluid can flow into the external measuring chamber with same liquid level as the level inside the container so that the level can be measured. This type transmitter is suitable to the measurement that the level is not convenient or difficult to be measured inside the container.

Installation Dimensions

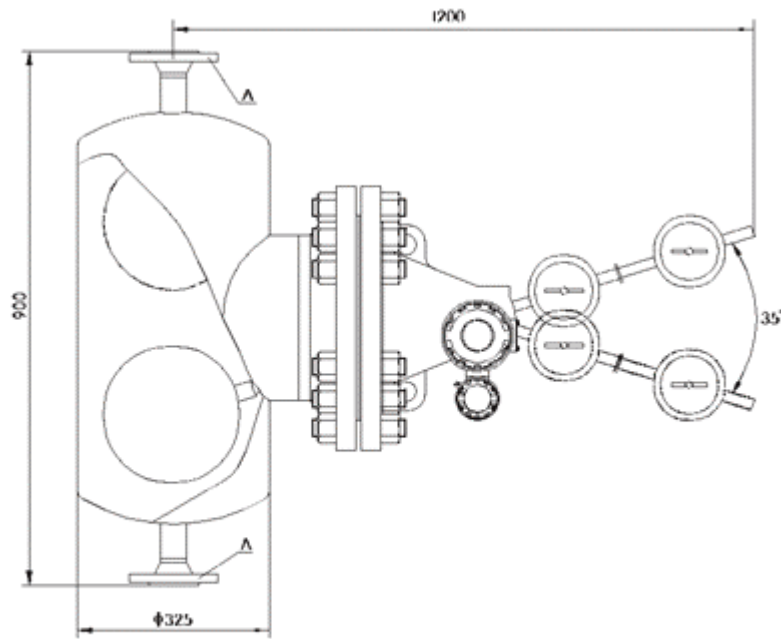

Dimensions of UQD.A-92 External Mounted Ball Float Type
UQD.Z-92

Note: Flange A is, DN 40, DN.0 or DN6.3Mpa JB/TB82.2-94 raised face flange

The support for the measuring chamber should be equipped by users themselves

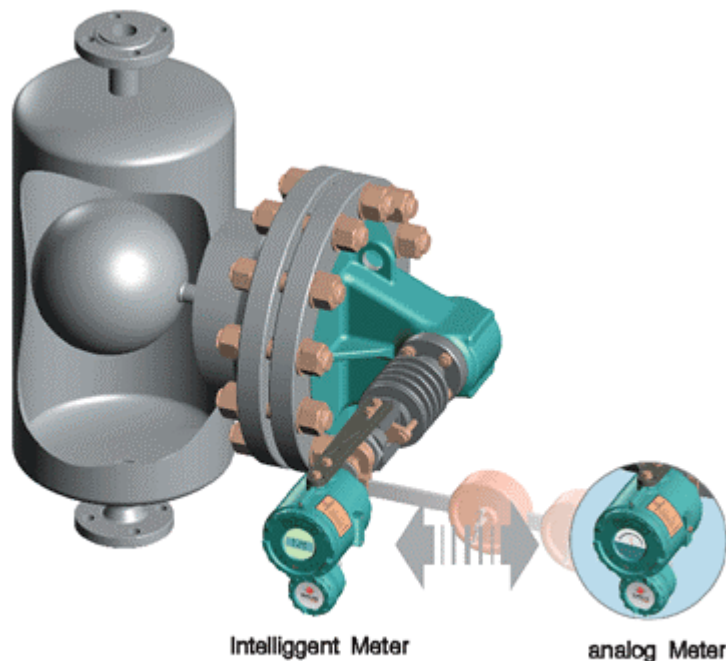

UQD.A-92 external Mounted Type Outline
UQD.Z-92

Model Selection Table

Model	Code		Code meaning
UQD			Electric ball-float liquid level transmitter
	A		Analog meter (head)
	B		Intelligent meter (head)
	-		
		90	Ordinary type
		91	Big angle type
		92	External mounting type
		A	Specially required flange standard and dimensions (please give the requirements in detail)
		B	JB/T82.2-94 PN4.0MPa, DN250
		C	JB/T82.2-94 PN6.3MPa, DN250
		-	
		i	Intrinsically safe
		d	Isolating explosion type
		T	Flange material: Carbon steel
		H	Flange material: 1Cr18Ni9Ti
		D	Fluid temperature: -40 ~ 225
		G	Fluid temperature: 225 ~ 450
UQD.	-	-	

Model selection example: UQD.A – 90B – iTG is ordinary type electric ball-float liquid level transmitter, analog meter (head), nominal pressure is 4.0MPa, nominal diameter is 250mm, intrinsically safe, flange material is carbon steel, fluid temperature is Fluid temperature: 225 ~ 450 , with radiator (radiating fin).

Explosion – proof

Model	UQD.A		UQD.Z	
	Intrinsically safe	Isolating explosion	Intrinsically safe	Isolating explosion
Explosion type	ia BT5	d BT4	ib CT4	d BT4
Ex-proof mark	ia BT5	d BT4	ib CT4	d BT4
Certificate No.	GYB02412	GYBO2164	GYB02165	GBY02164

Guard Grating Recommendation Table

Guard grating recommendation table	
Shanghai Intrinsic Safe Instrument System Co., Ltd	LS4041-Ex
Shanghai Automation Instrument Institute	GS8041-Ex, GS8045-Ex
Longfei Group Corporation in China	LF1045
British Company	MTL3046B, MTL5042, MTL706 ⁺
Germany P+F Company	KFD2-STC3-Ex ₁
Dandong Top Electronics Instrument Co., Ltd	TP5041-Ex, TP5045-Ex

Load Characteristic Chart

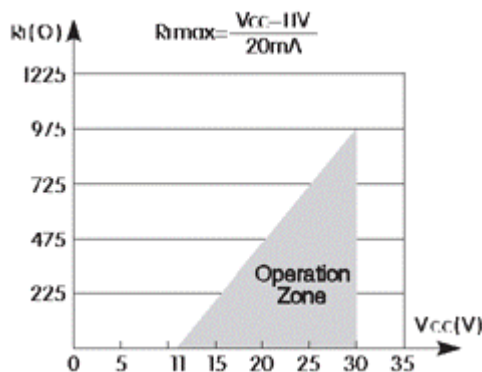

Order Notice

1. Select transmitter model correctly according to the model selection sheet.
2. Note the following parameter without being listed in the model selection sheet.

Operating pressure:

Special liquid contacting material brand

Installation tag No.:

Appendix

Range and Length of Ball Connecting Rod

$$L^* = \frac{H/2}{\sin(\theta/2)} - 115$$

L* ---- length of ball connecting rod (mm)

H ---- range (mm)

--- floating ball operating angle

* --- for UQD-91 big angle type electric ball-float liquid level transmitter, L includes the length of the arm that connects the ball connecting rod.

Example: float ball operating angle is 35°, measuring range is 500mm, to evaluate the length of connecting rod?

Using the formula to calculate the length of connecting rod:

$$L^* = \frac{500/2}{\sin(35^\circ/2)} - 115 = 718\text{mm}$$

Range and Length of Connecting Rod Parallel Table

Model	Range	Rod length
UQD-90 Ordinary type	400	551
	500	718
	600	885
	700	1051
	800	1218
	900	1385

	1000	1551
	1100	1718
	1200	1885
UQD-91 Big angle type	450	235
	500	274
	600	352
	700	430
	800	508
	900	585
	1000	663
	1100	741
	1200	819
	1300	897
	1400	975
1500	1053	
1600	1131	
UQD-92 External mounting type	330	435