

## ZBLB Intelligent Target Flow Transmitter

### Summary

ZBLB Intelligent Target Flowrate Transmitters adopts stress measuring method by applying the lever principle to acquires the signal being consistent with fluid flow rate change and being measured through high precision spectacles cantilever stress sensor. Via being processed by A/D converter, MPU and D/A converter, the signal is transferred into 4-20mA analog signal and digital signal that is in conformity with HART PROTOCOL and is superimposed on the analog signal, and then the processed signal is output. It is provided with the functions of high accuracy for linearity treatment, strong interfere- resistance, remote configuration, checking, maintenance and adjustment. This meter can work together with equipment being conformity with HART protocol in the field bus so as to realize the digital two-way communication, process checking and automatic controlling. It also is compatible with analog meter. It features pretty external appearance as its fashionable shell structure design. This structure makes each chamber separately to make the meter more reliable and safe. Also the meter is added a precise static pressure adjustment device so as to keep high precision and reliability. Both shell structure design and the static pressure adjustment device have been granted the national patents.



The patent number for external appearance design: 99 3 21507.6;

The patent number for static pressure adjustment device: 99 2 23728.9;

### Main Technical Parameters

#### Performances

- 1.LCD display: field display relative variables;
- 2.Local and remote configuration function: through the magnetic switch in the transmitters head, or a handle communicator or a computer with commissioning software to read, write and configure all kinds of process variables, the signal (4 ~ 20mA)on which every parameter and variables being conformity with HART protocol;
- 3.Self-diagnosis function: alarm when the fluid level exceeds the range and various failures occur;
- 4.Shock- resistance, electromagnetic interference resistance;
- 5.Zero point and full scale adjustments, no interference between the two kinds of adjustment;
- 6.Protection grade: IP65;
- 7.Flange standard: on request

#### Main technical parameters

Power supply: DC24V

Load Resistance: see the load characteristic curve;

Precision: 0.5% FS ( weighing method), 1.0% FS ( this accuracy will be supplied without any note);

Damping Period: 0 ~ 199 second

Max. integrated flux: 99.99MT;

Power supply inlet: M20×1.5;

Input impedance: > 100MΩ;

Nominal Pressure: 2.5, 4.0, 6.3MPa;

Ambient temperature: -40 °C - 70 °C

-25 °C - 70 °C (applying for local indication);

Operating temperature: see the transmitter head, ambient temperature and procedure temperature (figure 5);

Fluid density range: 300-1600kg/m<sup>3</sup>;

Flowrate range: 1.5 – 400 m<sup>3</sup>/h;

Flowrate range ratio: 3:1;

### Principle of Operation

A target plate is mounted at lower end of the lever 3. Fluid exerts a force F1 on target plate that is transferred to act at the lower end of the lever 3. Force F1 is transferred by lever3 to an upper end of lever1 and become force F2 with the gland seal diaphragm (has two functions: 1.act as the supporting point of the whole lever. 2. perform as a seal plate) as the supporting point. Lever1's upper end on which the force is exerted is connected with a weighing sensor, and then the force F2 transferred by lever1 is changed into a millivolt electric signal. The electric signal is transmitted out through A/D converter, microprocessor (MPU), D/A converter and signal transmitting circuit to finish a converting process. (See figure 1, figure 2)

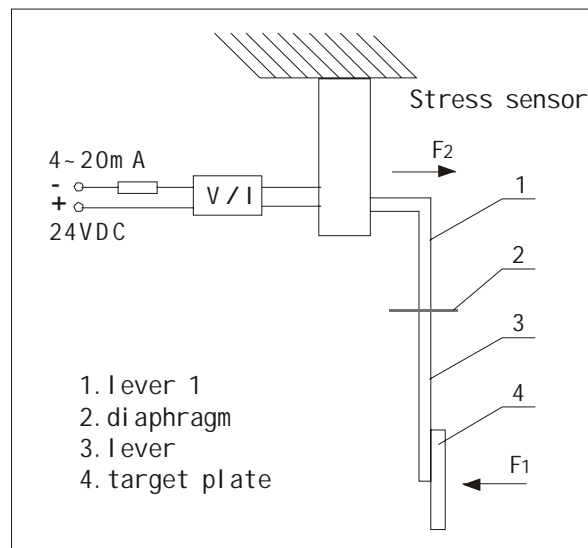

Figure 1. Structure principle sketch

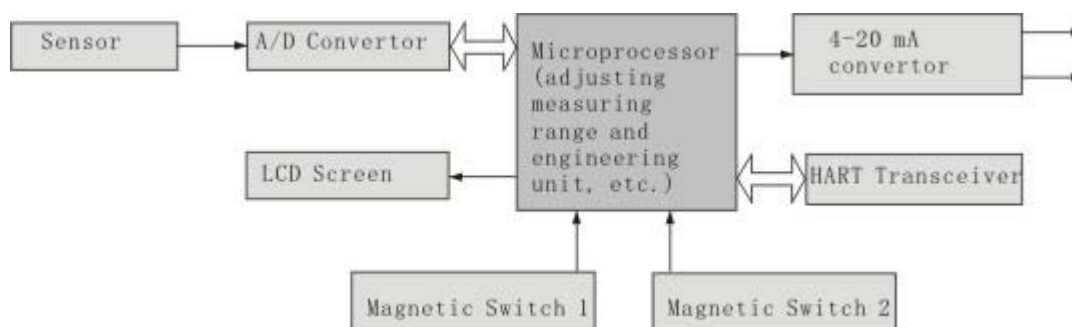

Figure 2. Electric principle diagram

**Model Selection Table**

Model	Code		Code meaning
ZBLB-			Intelligent Target Flow Transmitter
	1		PN : 2.5MPa
	2		PN : 4.0MPa
	3		PN : 6.3MPa
	015		DN15
	025		DN25
	040		DN40
	050		DN50
	080		DN80
	100		DN100
	150		DN150
	200		DN200
	A		Ring-type measuring chamber
	B		Straight pipe section measuring chamber
	/		
	i		Explosion-proof type: intrinsically safe ex-proof
	T		Wetted material: carbon steel
	H		Wetted material: 1Cr18Ni9Ti
		D	Without radiating flange see figure 5
		G	With radiating flange see figure 5
		X	With auxiliary local device ( please note radiation or insulation) see figure 5
			Fluid density:300 ~ 1600kg/m <sup>3</sup>
		Q□	Max. volume flowrate m <sup>3</sup> /h
		G□	Max. mass flowrate t/h
ZBLB-			

**Model description:**

ZBLB-2050A/ iTD780G20 is intelligent target flowrate transmitter, nominal pressure is 4.0MPa, nominal diameter is 50mm, ring-type measuring chamber, intrinsically safe explosion-proof, the measuring chamber material is carbon steel, without radiating flange, fluid density is 780 kg/m<sup>3</sup>, maximum mass flowrate is 20t/h.

**Flowrate Table (calibrated fluid's density is 839kg/m<sup>3</sup>)**

Nominal diameter DN(mm)	Target diameter (mm)	$=d/D$	Flowrate coefficient K	C 14.129×D (1/β - β)	Flowrate range m <sup>3</sup> /h
15	12	0.80	0.699	95.370	1.5,4
25	20	0.80	0.725	158.951	4,5,6,3
	18	0.72	0.690	236.268	8
40	28	0.70	0.701	411.759	8
	32	0.80	0.741	254.322	6.3
50	40	0.80	0.725	317.902	8,10,12.5
	35	0.70	0.675	514.699	16, 20
	30	0.60	0.650	753.546	25
80	56	0.70	0.680	823.518	25,32
	48	0.60	0.660	1205.674	40,50
	40	0.50	0.660	1695.480	63
100	70	0.70	0.660	1029.398	40
	60	0.60	0.660	1507.093	50,63
	50	0.50	0.650	2119.350	80
	40	0.40	0.650	2967.090	100
150	90	0.60	0.660	2260.640	80
	75	0.50	0.660	3179.025	100,125
	60	0.40	0.650	4450.635	160
200	70	0.35	0.660	7084.684	160,200,250
	50	0.25	0.660	10596.750	300,400

**Outline and Installation Dimension**

ZBLB-□□A/□□D□□ (ring-type measuring chamber)

ZBLB-□□B/□□D□□ (straight pipe section measuring chamber)

Nominal diameter (mm)	L	M
15	355	60
25	365	60
40	375	70
50	400	70
80	395	70
100	415	90
150	460	110
200	505	120

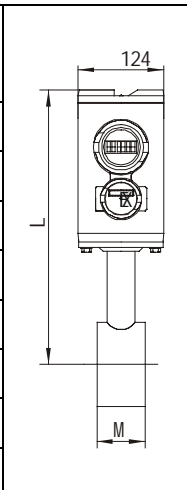

Nominal diameter (mm)	L	M	M1
25	365	250	125
40	375	280	140
50	400	300	150
80	395	350	175
100	415	400	200
150	460	500	250
200	505	600	300

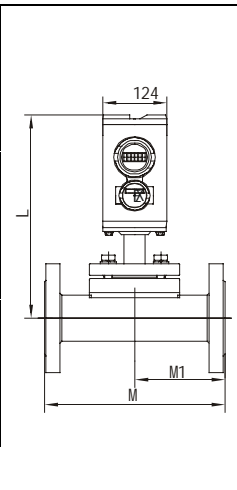

ZBLB-□□A/□□G□□ (ring-type measuring chamber)      ZBLB-□□B/□□G□□ (straight pipe section measuring chamber)

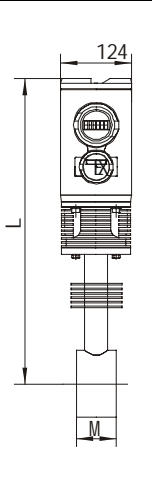
Nominal diameter (mm)	L	M		
15	512	60		
25	527	60		
40	542	70		
50	557	70		
80	572	70		
100	592	90		
150	637	110		
200	667	120		

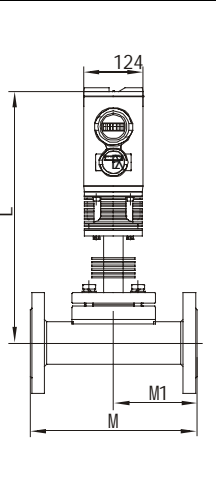
Nominal diameter (mm)	L	M	M1		
25	527	250	125		
40	542	280	140		
50	557	300	150		
80	572	350	175		
100	592	400	200		
150	637	500	250		
200	667	600	300		

ZBLB-□□A/□□X□□ (ring-type measuring chamber)

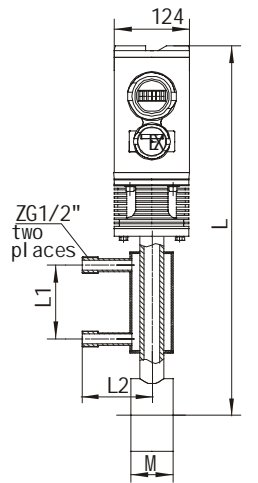
Nominal diameter (mm)	L	M	L1	L2		
15	512	60	102	85		
25	527	60	99	90		
40	542	70	100	90		
50	557	70	108	90		
80	572	70	108	90		
100	592	90	108	90		
150	637	110	116	90		
200	667	120	102	90		

ZBLB-□□B/□□X□□ (straight pipe section measuring chamber)

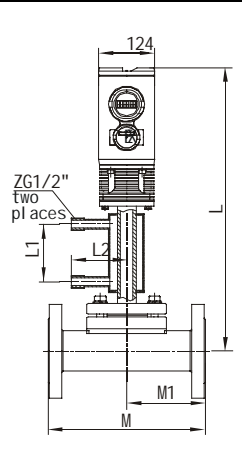
Nominal diameter (mm)	L	M	M1	L1	L2		
25	527	250	125	88	90		
40	542	280	140	92.5	95		
50	557	300	150	92	115		
80	572	350	175	92	115		
100	592	400	200	92	115		
150	637	500	250	111	135		
200	667	600	300	106	135		

Note:

Flanges should be furnished by user according to the pressure rating and flange standards.

Female flange should be outfit to the transmitter with ring-type measuring chamber, while the raised face flange should be outfit to the transmitter with straight pipe section measuring chamber.

### Explosion-proof

Explosion-proof type	Intrinsically safe explosion-proof
Explosion-proof sign	ia CT4
Explosion certificate number	GYB99271

### Guard Grating Recommendation Table

Guard grating recommendation table	
Dandong Top Electronics Instrument Co.,Ltd	TP5041-Ex; TP5045-Ex
Shanghai Automation Instrument Institute	GS8041-Ex; GS8037-Ex
TURCK company	MK33-11Ex-Hli/24VDC
British MTL company	MTL3046B; MTL5042
Germany P+F company	KFD2-STC3-Ex1

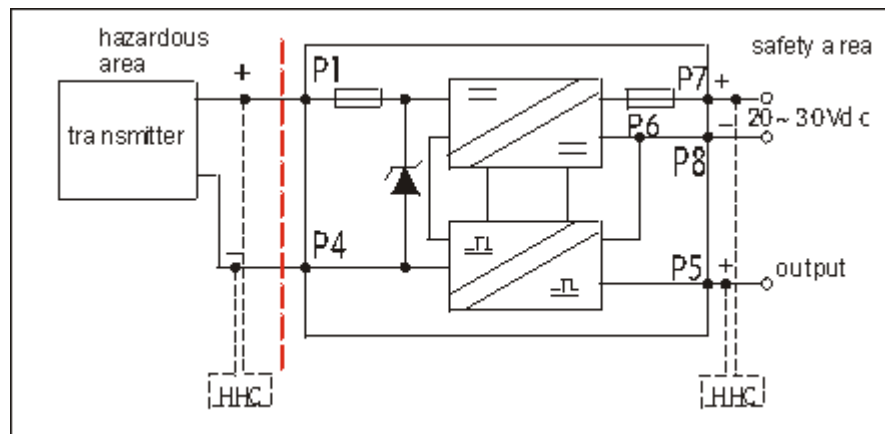

figure 3: electric system schematic diagram

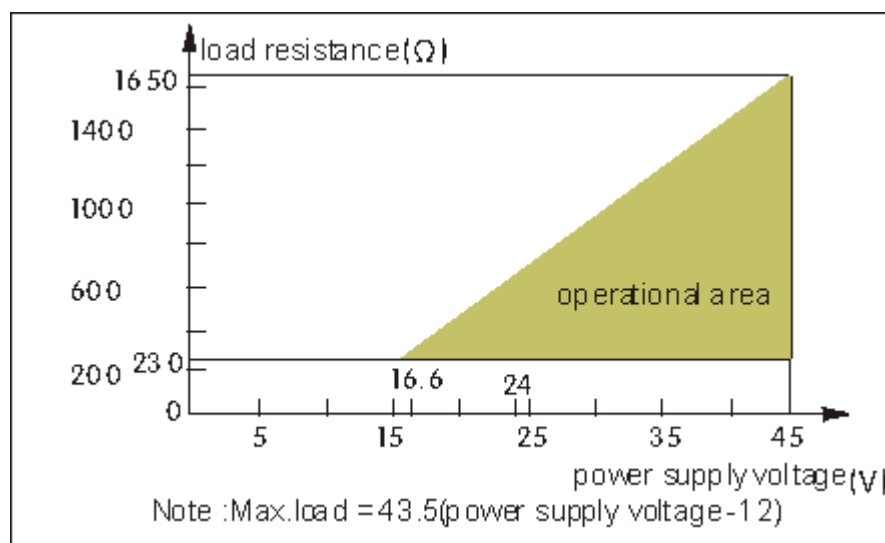

figure 4: load character diagram

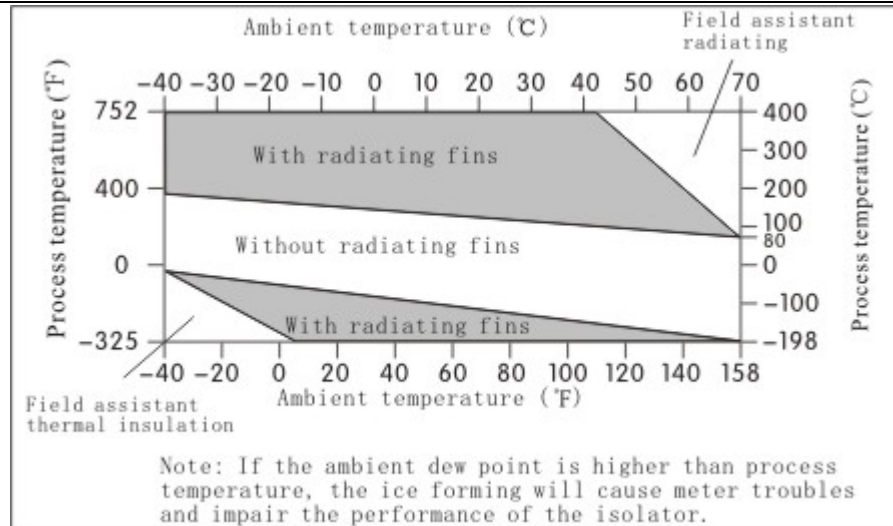

figure 5: look-up table for transmitter head and ambient temperature and procedure temperature.

## Order Notice

Please fill in the order sheet when purchasing.

Model			Tag No.		Quantity	
Operation	Fluid		Max.Flowrate			(kg/h)
	Oper. Temper.	(°C)				(m <sup>3</sup> /h)
	Oper. Press.	(MPa)	Norm.Flowrate			(kg/h)
Fluid Density	(kg/m <sup>3</sup> )				(m <sup>3</sup> /h)	
Condition	Kinematic Vis.	(mm <sup>2</sup> /s)	Min. Flowrate			(kg/h)
	Dynamic Vis.	(mPa.s)				(m <sup>3</sup> /h)
	Flange Stand.		Pipe state			horizontal pipe vertical pipe
Remark:						

Note:

- When the transmitter is installed in pipeline vertically, the flow direction should be from down to up;
- Straight pipe sections should be fitted fore and rear the transmitter. The length of the upstream straight pipe section should not less than 10 times nominal diameter of the pipe, while the length of the downstream pipe section should not less than 5 times nominal diameter of the pipe;
- The meter should not be installed in an environment with violent vibration.
- A pass-by pipe should be installed in parallel and be connected to both inlet and outlet of the meter with a cut-off valve fitted.

Note: The customer prepare the connection flange by himself on pressure class and the performed standard of the flange.

Circular measuring compartment is equipped with concave flange

The measuring compartment of straight pipeline section is equipped with convex flange.

The meter shall not be installed in a place subjected to vigorous vibration.

Both sides of instrument should be equipped with by-pass pipeline.

The meter can measure the fluid in direction of horizontal or vertical, the

vertical fluid flows from downward to upward.

The upstream and downstream of the meter shall be fitted with a certain length straight pipeline, the length of pipe in the upper stream shall not be short than 10 times of nominal diameter, and not be short than 5 times of nominal diameter in the down stream.

## Order Requirements

- 1) Please fill in the form correctly according to the products selection table
- 2) Please note the information exclude in products selection table
  - a. Normal flowrate
  - b. Operation pressure
  - c. The nameplate of special wetted material
  - d. Location chart for meter installation
  - e. Vertical pipeline installed in vertical, please note special
  - f. Meter accuracy class (Supply on 1.0% FS, without note)
  - g. Operation temperature